

Model 59090-Series

DIAPHRAGM WASTE PUMP

FEATURES

- Self-priming to a lift of six feet
- Flow rate to 6-1/2 gallons per minute
- Rated for continuous duty cycles of up to 1/2 hour of uninterrupted pumping time (nearly 200 gallons of sewage transfer per cycle)
- Motor meets USCG regulation 183.410 and ISO 8846 MARINE for ignition protection
- Motor is EMC compliant and **CE** marked.
- Ports accept 1-1/2" hose with room for double band clamps
- All pump components (non-flexible) are non-corrosive plastic, stainless steel and bronze
- Diaphragm is made of Santoprene* and the valves are made of nitrile
- Pump housing is made of glass filled nylon
- The motor and gear drive are painted with a durable protective coating
- A plastic motor splash guard adds additional protection

VARIATIONS AVAILABLE

MODEL NO.	DESCRIPTION
59090-0012	12V DC
59090-0024	24V DC

APPLICATION

The Jabsco Diaphragm Waste Pump offers a dependable method of emptying waste holding tanks. With no mechanical moving parts in contact with the fluid being pumped, it can handle both macerated and non-macerated waste.

Simplicity of design makes it extremely reliable and capable of passing nearly any solids that are typically included in waste holding tank solutions. Because of its superior solids handling ability, it can also be used for bait tank evacuation and other applications with occasional small suspended solids in the fluid being pumped.

It is very quiet running and can run completely dry for extended periods of time without pump damage. All moving mechanical parts are fully shrouded for maximum safety. The removal of a single clamp ring screw allows the entire motor, gear drive and upper pump



Model 59090-Series

housing with diaphragm assembly to be lifted off the pump body.

INSTALLATION

The pump may be secured to any solid mounting surface. For ease of service, it is best mounted horizontally in an accessible location slightly higher than the highest potential liquid level in the holding tank. It may be mounted on a slight angle up to about thirty degrees. The pump may be mounted to a vertical surface but only if the inlet port is positioned down and discharge port up. This mounting position can improve primeability in installations with higher discharge heads. In fact, if the suction lift of the pump is two feet (0.6M) or more and the pump must pump against an additional discharge head, the vertical pump mounting is required. The maximum total system head must not exceed six feet. It should ideally be located slightly higher than the discharge thru-hull. If this can not be done, to avoid tank and plumbing drainage during service, an adequate length of flexible hose should be provided in both the inlet and discharge plumbing so the pump with hoses attached can be temporarily raised and supported horizontally above the tank's maximum liquid level and the discharge thru-hull. Alternatively, 1-1/2" "Full Port" valves (full 1-1/2" ID when open) can be installed as close as possible to the pump ports to minimize drainage of effluent during service.

The plumbing should be routed so it is as short and straight as possible. Ideally, it should not include low spots that would become water traps. Generally, the waste discharge plumbing should be connected to a thru-hull that is positioned to remain above the waterline at all angles of heel and trim. Sailboats should generally discharge astern where the thru-hull will not drop below the water line while underway.

* Santoprene is a trade mark of Monsanto Corporation.

** Complies with EN 50081-2 for suppression of electro-magnetic interference.

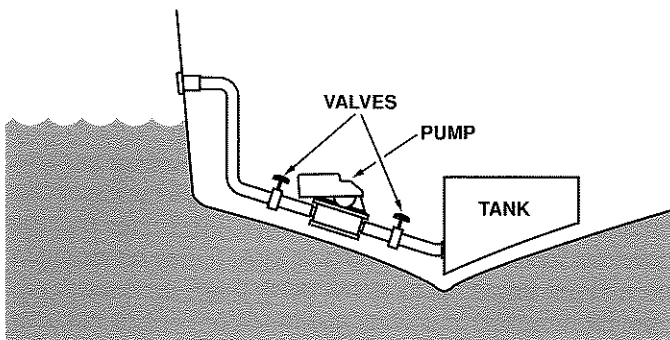
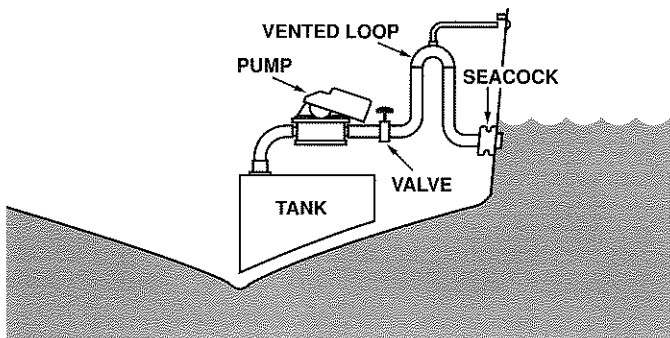
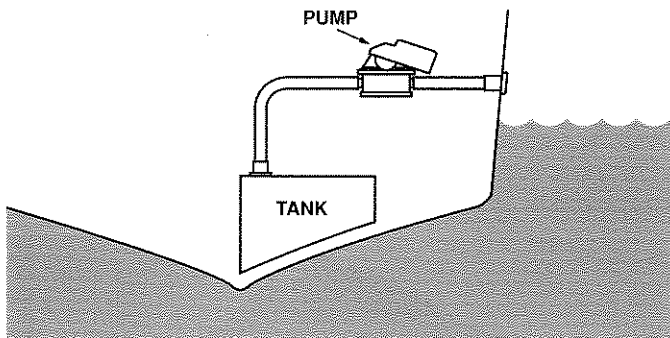

If the waste discharge plumbing can not be connected to a thru-hull positioned above the water line, the discharge plumbing must be fitted with a 1-1/2" vented loop positioned to remain about 8" above the water line at all angles of heel and trim.

Position the pump in its intended mounting place with inlet port (fitted with flapper valve) and discharge port (fitted with joker type valve) aligned with the appropriate plumbing. Mark the location of the four mounting holes in the pump's base. In each of the four positions drill a suitably sized hole for the fasteners being used to secure the pump. Before mounting the pump, check that the pump's clamp ring screw will be accessible after the pump is installed. If it will not be accessible, loosen the clamp screw and reposition the clamp ring. Fasten the pump to its mounting surface. Slide the 1-1/2" inlet and discharge hoses completely onto the port fittings and secure them with two non-corrosive band clamps on each port.

Connect the motor's electrical leads to the vessel's DC power supply using properly sized wires determined from the Electrical Specifications Chart below. Connect the motor's red lead to positive and black lead to negative. Connect the positive conductor to the vessel's power source through an over-current protected distribution panel

with appropriate sized fuse or circuit breaker. Include in the positive lead in a convenient location an On/Off switch with a minimum current rating of 10 amps. All wire connections should be made with mechanical locking connectors (crimp type) and wires should be secured at 18" intervals along the entire length of their run.

MODEL NO.	VOLTAGE	NOM. FUSE		WIRE SIZE/TOTAL LENGTH*		
		AMPS	BRKR.	0'-25'	25'-40'	40'-60'
59090-0012	12V DC	7	15	16 (1.5)	14 (2.5)	12 (4)
59090-0024	24V DC	4	10	16 (1.5)	16 (1.5)	16 (1.5)

* Total length is the sum of both the positive and negative conductors measured from the power source to the pump and back to ground. Wire sizes provided in SAE gage diameters and (ISO millimeter) diameters.

MAINTENANCE

The Jabsco Diaphragm Waste Pump should provide many hours of trouble free service. It requires no regular scheduled maintenance other than occasional replacement of the rubber diaphragm and valves. Over extended periods of time they can become stiff and cause diminished performance. Normally, the rubber parts should be expected to last several seasons with very little deterioration.

Should the pump fail to prime, or a noticeable reduction in flow is detected, the cause may be either deteriorating rubber parts or possibly a blockage in either of the pump valves. The pump chamber can be accessed and inspected to determine if either above condition exists. However, prior to doing any service work, ensure that power to the pump is turned off and the pump is positioned horizontally and above the highest possible liquid level in the holding tank and plumbing system. Or, if applicable, close both valves near the pump ports and place the pump in a drip pan with adequate capacity to catch liquid in the hoses between the valves and the pump.

To inspect the valves and both sides of the diaphragm loosen the pump's clamp ring screw and remove the clamp ring from the pump body and upper housing. The complete motor and upper housing assembly with diaphragm attached can then be lifted from the pump body. Both sides of the diaphragm can then be inspected for cracks or abrasion. It should be soft and flexible. If it is stiff or damaged, it should be replaced. To do this, remove the locking nut from the bolt that secures the lower diaphragm plate to the upper one. Remove the lower diaphragm plate and diaphragm. Position a new diaphragm with the raised center area toward the motor and against the upper diaphragm plate. Reposition the lower diaphragm plate on the bolt and secure it with the locking nut.

Both valves can also be inspected with the upper housing and diaphragm assembly removed. The inlet valve is a flapper type valve and should lay flat against the seal seat in its relaxed state. The discharge valve is a triadic joker type valve and the three slits in the end of the valve should be closed in its relaxed state. Any debris lodged in either valve should be removed. Both valves should be soft and flexible.

To replace the valves, remove the four screws that secure each port to the body and pull the port away from the body. The valves can then be removed and replaced and the ports resecured to the body.

To replace the pump's motor, first disconnect the motor's two wire leads from the electrical connections. Then, loosen the pump's clamp ring screw and remove the clamp ring from the pump body and upper housing. The complete motor and upper housing assembly with diaphragm attached can then be lifted from the pump body. Using a flat blade screwdriver, dislodge the upper housing's crank arm access plate. Remove the screw and washers that secure the connecting rod to the crank arm on the motor. Slide the connecting rod off the crank arm taking care not to lose the washer behind the connecting rod. Remove the motor by removing the three screws that hold the motor gear housing to the pump's upper housing.

Slide the shaft of the replacement motor with its crank arm attached through the hole in the upper housing and secure the motor in place with the three machine screws and lock washers. Slide one plastic washer over the crank arm and position the connecting rod with diaphragm attached on the crank arm. Secure the connecting rod to the crank arm with the crank arm screw lock washer and remaining plastic washer. Reposition the upper housing assembly on the pump body ensuring the diaphragm is properly seated in position and secure the two assemblies together with the clamp ring. Tighten the clamp ring screw until there is approximately a 3/16" space between the ends of the clamp halves. Reconnect the motor's wire leads to the power source conductors.

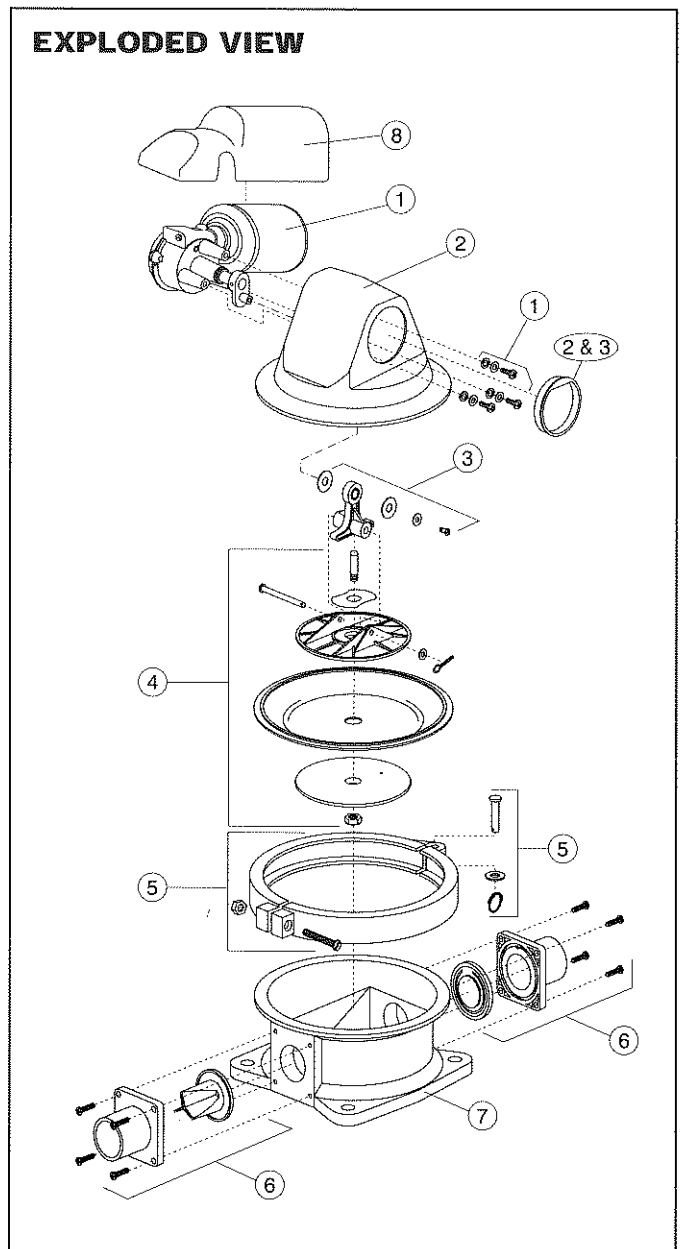

PARTS LIST

Key	Description	Part Number
1	Motor Kit with 12V DC	18328-0012
	Crank Arm 24V DC	18328-0024
2	Upper Housing Kit	59093-1000
3	Connecting Rod Assy.	59095-1000
4	Diaphragm and Plate Kit	29277-1000
5	Clamp Ring Kit	29252-1000
6	Ports Kit	29275-1000
7	Body Kit	59091-1000
8	Splash Guard	59094-1000
	Service Kit *	90220-0000

*The service kit contains 1 diaphragm, 1 inlet valve, 1 discharge valve, 1 diaphragm retaining lock nut and 3 spare port retaining rings.

DIMENSIONAL DRAWING
Inches (Millimeters)

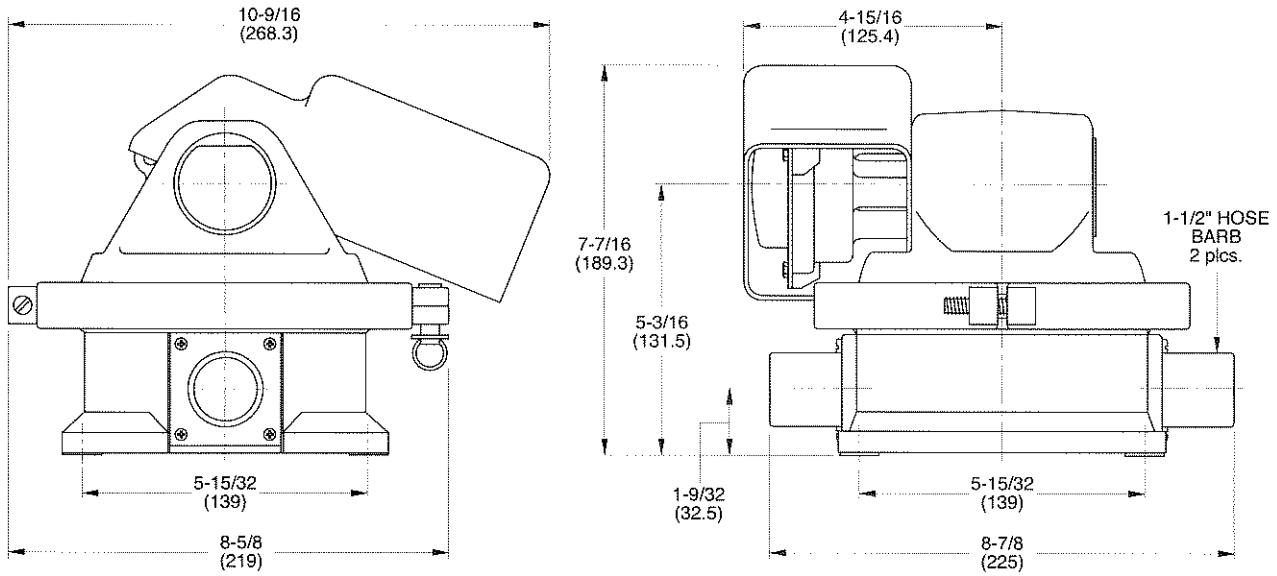

Jabsco



ITT Industries
Engineered for life

THE PRODUCTS DESCRIBED HEREIN ARE
SUBJECT TO THE JABSCO ONE YEAR LIMITED
WARRANTY, WHICH IS AVAILABLE FOR YOUR
INSPECTION UPON REQUEST.

U.S.A.
Jabsco
Cape Ann Industrial Park
Gloucester, MA 01930
Tel: 978.281.0440
Fax: 978.283.2619

UNITED KINGDOM
Jabsco
Bingley Road, Hoddesdon
Hertfordshire EN11 0BU
Tel: +44 (0) 1992 450145
Fax: +44 (0) 1992 467132

CANADA
Fluid Products Canada
55 Royal Road
Guelph, Ontario N1H 1T1
Tel: (519) 821.1900
Fax: (519) 821.2569

JAPAN
NHK Jabsco Company Ltd.
3-21-10, Shin-Yokohama
Kohoku-Ku, Yokohama, 222
Tel: 045.475.8906
Fax: 045.475.8908

GERMANY
Jabsco GmbH
Oststrasse 28
22840 Norderstedt
Tel: +49-40-53 43 73 -0
Fax: +49-40-53 53 73 -11